

7.869 ACRES (342,797 SQ. FT.)

SAMUEL MITCHELL SURVEY ~ ABSTRACT NO. 593

BEING A 7.869 ACRE TRACT OF LAND LOCATED IN THE SAMUEL MITCHELL SURVEY, ABSTRACT NO. 593, CITY OF MANSFIELD, JOHNSON COUNTY, TEXAS, BEING ALL OF A CALLED 7.875 ACRE TRACT OF LAND AS DESCRIBED IN THE SPECIAL WARRANTY DEED TO L.R. RAY, TRUSTEE OF THE L.R. RAY AND TOMMIE A. RAY TRUST DATED JANUARY 18, 1994, FILED FOR RECORD IN COUNTY CLERK'S INSTRUMENT NO. 2013-07246, OFFICIAL PUBLIC RECORDS, JOHNSON COUNTY, TEXAS (OPRJCT), SAID 7.869 ACRE TRACT OF LAND BEING MORE PARTICULARLY DESCRIBED BY METES AND BOUNDS AS FOLLOWS:

ATTENTION TO SCHEDULE B ITEMS *

- 10. THE FOLLOWING MATTERS AND ALL TERMS OF THE DOCUMENTS CREATING OR OFFERING EVIDENCE OF THE MATTERS (WE MUST INSERT MATTERS OR DELETE THIS EXCEPTION):
a. ALL LEASES, GRANTS, EXCEPTIONS OR RESERVATIONS OF COAL, LIGNITE, OIL, GAS AND OTHER MINERALS, TOGETHER WITH ALL RIGHTS, PRIVILEGES, AND IMMUNITIES RELATING THERETO, APPEARING IN THE PUBLIC RECORDS WHETHER LISTED IN SCHEDULE B OR NOT. THERE MAY BE LEASES, GRANTS, EXCEPTIONS OR RESERVATIONS OF MINERAL INTEREST THAT ARE NOT LISTED.
NOT ADDRESSED BY SURVEYOR
b. ALL ENCUMBRANCES, VIOLATIONS, VARIATIONS, OR ADVERSE CIRCUMSTANCES AFFECTING TITLE THAT WOULD BE DISCLOSED BY AN ACCURATE AND COMPLETE LAND SURVEY OF THE LAND, INCLUDING, WITHOUT LIMITATION, ALL VISIBLE AND APPARENT EASEMENTS OR USES AND ALL UNDERGROUND EASEMENTS OR USES, THE EXISTENCE OF WHICH MAY ARISE BY UNRECORDED GRANT OR BY USE. (MAY BE AMENDED OR DELETED UPON APPROVAL OF SURVEY.)
NOT ADDRESSED BY SURVEYOR
c. RIGHTS, IF ANY, OF THIRD PARTIES WITH RESPECT TO ANY PORTION OF THE SUBJECT PROPERTY LYING WITHIN THE BOUNDARIES OF A PUBLIC OR PRIVATE ROAD. (MAY BE AMENDED OR DELETED UPON APPROVAL OF SURVEY.)
NOT ADDRESSED BY SURVEYOR
d. RIGHTS OF PARTIES IN POSSESSION AND RIGHTS OF TENANTS UNDER ANY UNRECORDED LEASES OR RENTAL AGREEMENTS. (MAY BE AMENDED OR DELETED UPON EXECUTION OF SATISFACTORY AFFIDAVIT WITH RESPECT TO PARTIES IN POSSESSION AND TENANTS AT CLOSING.)
NOT ADDRESSED BY SURVEYOR
e. UNDIVIDED ROYALTY INTEREST IN COAL, LIGNITE, OIL, GAS AND OTHER MINERALS, AND ALL RIGHTS INCIDENT THERETO, DESCRIBED IN INSTRUMENT FILED 02/28/1956, RECORDED IN VOLUME 407, PAGE 16, REAL PROPERTY RECORDS, JOHNSON COUNTY, TEXAS. COMPANY MAKES NO REPRESENTATION AS TO THE PRESENT OWNERSHIP OF ANY SUCH INTERESTS.
MAY AFFECT THE SUBJECT PROPERTY. HOWEVER, THE SURVEYOR RECOMMENDS AN ATTORNEY'S OPINION ON THE LANGUAGE CONTAINED THEREIN.
f. UNDIVIDED ROYALTY INTEREST IN COAL, LIGNITE, OIL, GAS AND OTHER MINERALS, AND ALL RIGHTS INCIDENT THERETO, DESCRIBED IN INSTRUMENT FILED 10/26/1981, RECORDED IN VOLUME 881, PAGE 354, REAL PROPERTY RECORDS, JOHNSON COUNTY, TEXAS. COMPANY MAKES NO REPRESENTATION AS TO THE PRESENT OWNERSHIP OF ANY SUCH INTERESTS.
DOES APPEAR TO AFFECT THE SUBJECT PROPERTY
g. MINERAL LEASE TOGETHER WITH ALL RIGHTS, PRIVILEGES AND IMMUNITIES INCIDENT THERETO, TO CARTER-GIFFORD OIL COMPANY FROM ARTHUR LEE MOORE AND WANDALEA MOORE DESCRIBED IN INSTRUMENT FILED 09/12/1961, RECORDED IN VOLUME 11, PAGE 390, REAL PROPERTY RECORDS, JOHNSON COUNTY, TEXAS. COMPANY MAKES NO REPRESENTATION AS TO THE PRESENT OWNERSHIP OF ANY SUCH INTERESTS.
DOES APPEAR TO AFFECT THE SUBJECT PROPERTY
h. MINERAL LEASE TOGETHER WITH ALL RIGHTS, PRIVILEGES AND IMMUNITIES INCIDENT THERETO, TO DAVID H. ARRINGTON OIL & GAS, INC. FROM LEE ROY RAY DESCRIBED IN INSTRUMENT FILED 09/07/2005, RECORDED IN VOLUME 3618, PAGE 35, REAL PROPERTY RECORDS, JOHNSON COUNTY, TEXAS. COMPANY MAKES NO REPRESENTATION AS TO THE PRESENT OWNERSHIP OF ANY SUCH INTERESTS.
DOES APPEAR TO AFFECT THE SUBJECT PROPERTY. HOWEVER, THE TERM OF 2 YEARS NEEDS TO BE EVALUATED BY AN ATTORNEY.
i. FIFTEEN FOOT UTILITY EASEMENT OVER AND ACROSS NORTHWESTERLY SIDE OF PROPERTY AS SET OUT IN WARRANTY DEED, FILED 10/26/1981, RECORDED IN VOLUME 881, PAGE 354, REAL PROPERTY RECORDS, JOHNSON COUNTY, TEXAS.
DOES AFFECT THE SUBJECT PROPERTY AS SHOWN HEREON
j. EASEMENT GRANTED BY LEE ROY RAY TO PEREGRINE PIPELINE COMPANY, LP, FILED 06/19/2007, RECORDED IN VOLUME 4121, PAGE 202, REAL PROPERTY RECORDS, JOHNSON COUNTY, TEXAS.
DOES AFFECT THE SUBJECT PROPERTY AS SHOWN HEREON

SURVEYOR'S CERTIFICATE *

CERTIFIED TO: FIRST AMERICAN TITLE GUARANTY COMPANY, REUNION TITLE AND L.R. RAY, TRUSTEE OF THE L.R. RAY AND TOMMIE A. RAY FAMILY TRUST DATED JANUARY 18, 1994.

THE UNDERSIGNED (THE "SURVEYOR") HEREBY CERTIFIES THAT THE ATTACHED SURVEYS MEETS THE REQUIREMENTS OF A CATEGORY 1A, CONDITION II, LAND TITLE SURVEY, AS OUTLINED IN THE TSPS MANUAL OF PRACTICE FOR LAND SURVEYING IN THE STATE OF TEXAS. THE PROPERTY LINES SHOWN HEREON ARE TRUE AND CORRECT, AND PREPARED FROM AN ACTUAL ON-THE-GROUND SURVEY OF THE REAL PROPERTY. SUCH SURVEYS WERE CONDUCTED BY THE SURVEYOR OR UNDER HIS DIRECT SUPERVISION. ALL MONUMENTS SHOWN HEREON ACTUALLY EXIST, AND THE LOCATION AND TYPE OF MATERIAL THEREOF ARE CORRECTLY SHOWN. ALL EASEMENTS, SETBACKS ARE FROM THE PLAT OF RECORD FOR THE SUBJECT PROPERTY.

MERLE W. MILLER DATE: 12-10-2021 REGISTERED PROFESSIONAL LAND SURVEYOR NO. 5438 STATE OF TEXAS



PLEASE NOTE THAT THE USE OF THE WORD "CERTIFY" OR "CERTIFICATE" USED HEREON CONSTITUTES AN EXPRESSION OF PROFESSIONAL OPINION REGARDING THOSE FACTS OF FINDINGS WHICH ARE THE SUBJECT OF THE CERTIFICATION, AND DOES NOT CONSTITUTE A WARRANTY OF GUARANTEE, EITHER EXPRESSED OR IMPLIED.

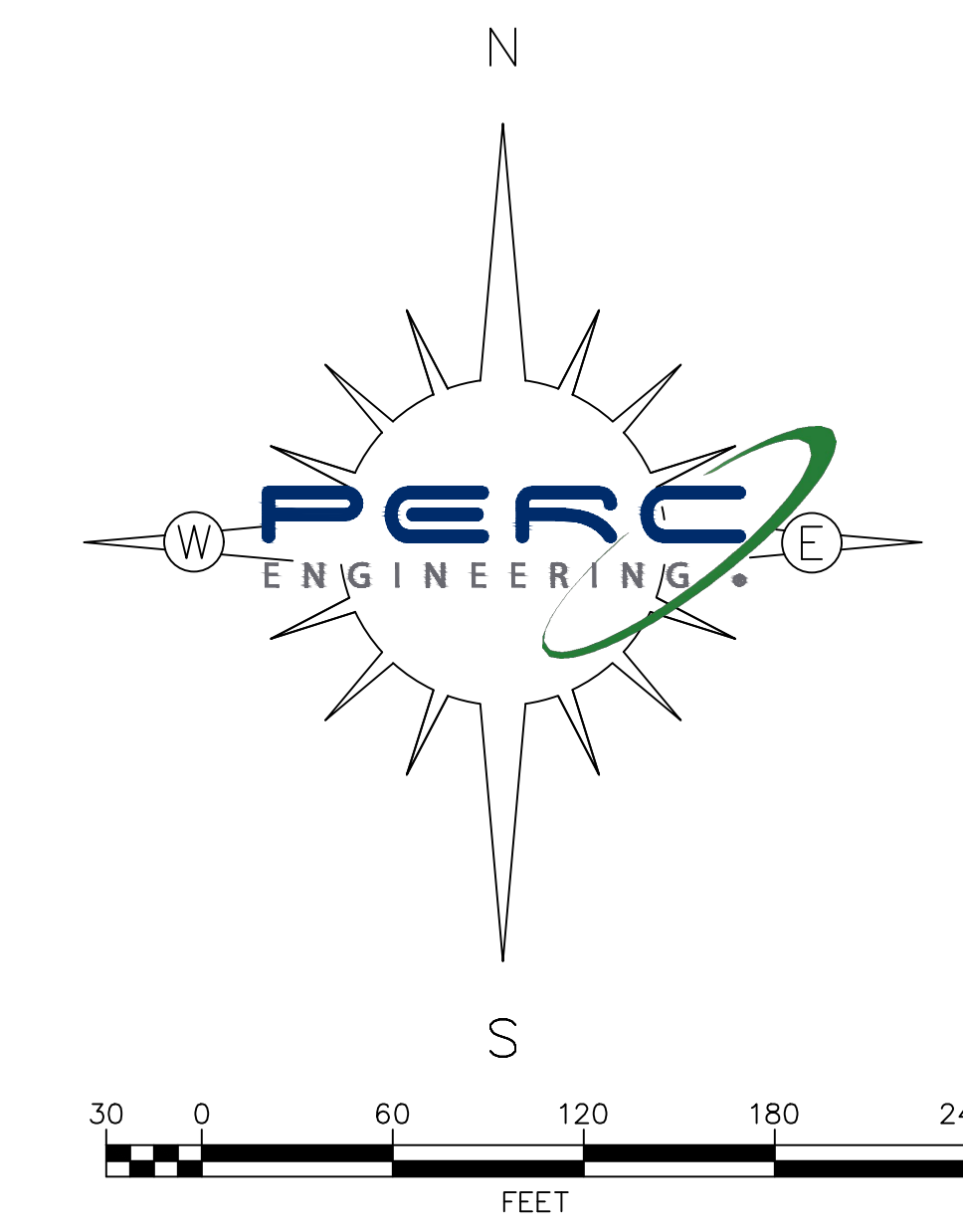

GENERAL NOTES *

- 1. THE BEARINGS SHOWN HEREON ARE IN REFERENCE TO THE TEXAS COORDINATE SYSTEM - NORTH CENTRAL ZONE, 4202, BASED ON GPS OBSERVATION UTILIZING THE LEICA GPS REFERENCE NETWORK.
2. THIS SURVEY WAS PREPARED WITH THE BENEFIT OF THE COMMITMENT FOR TITLE INSURANCE ISSUED BY FIRST AMERICAN TITLE GUARANTY COMPANY, OF NO. 2017-351240-RL, EFFECTIVE DATE: OCTOBER 15, 2021, ISSUED: NOVEMBER 01, 2021. THE EASEMENTS, RIGHTS-OF-WAY OR OTHER EXCEPTIONS NOTED HEREON ARE ACCORDING TO SCHEDULE "B" THEREIN. THIS SURVEYOR HAS NOT ABSTRACTED THE PROPERTY.
3. THIS LAND TITLE SURVEY IS OF A TRACT OF LAND AS DESCRIBED IN COUNTY CLERK'S INSTRUMENT #2013-07246, DEED RECORDS, JOHNSON COUNTY, TEXAS.
4. THE SUBJECT PROPERTY IS LOCATED IN ZONE "X", AREAS OF 0.2% ANNUAL CHANCE FLOOD; AREAS OF 1% ANNUAL CHANCE FLOOD WITH AVERAGE DEPTHS OF LESS THAN 1 FOOT OR WITH DRAINAGE AREAS LESS THAN 1 SQUARE MILE; AND AREAS PROTECTED BY LEVEES FROM 1% ANNUAL CHANCE FLOOD; AREAS DETERMINED TO BE OUTSIDE THE 0.2% ANNUAL CHANCE FLOODPLAIN, ACCORDING TO THE FLOOD INSURANCE RATE MAP (FIRM), MAP NUMBER 48251C0125J, MAP REVISED DECEMBER 4, 2012. THE SURVEYOR HAS NOT PERFORMED A STUDY OF THE LIMITS OF THE FLOODPLAIN AND THIS DESIGNATION IS BASED SOLELY ON OVERLAYING THE FLOOD MAP ONTO THE SUBJECT TRACT.
5. SUBSURFACE AND ENVIRONMENTAL CONDITIONS WERE NOT EXAMINED OR CONSIDERED AS PART OF THIS SURVEY. NO STATEMENT IS MADE CONCERNING THE EXISTENCE OF UNDERGROUND OR OVERHEAD CONTAINERS OR FACILITIES THAT MAY AFFECT THE USE OR DEVELOPMENT OF THE SUBJECT PROPERTY.

NOT ALL WILL APPLY LEGEND & ABBREVIATIONS

Table with 2 columns of symbols and their corresponding abbreviations for various survey features like roof drains, mail boxes, manholes, etc.

ZC#23-006 EXHIBIT A CATEGORY 1A, CONDITION II LAND TITLE SURVEY 7.869 ACRES OF LAND LOCATED IN THE SAMUEL MITCHELL SURVEY, ABSTRACT NO. 593 CITY OF MANSFIELD, JOHNSON COUNTY, TEXAS



4055 INTERNATIONAL PLAZA, STE 430 FORT WORTH, TX 76109 MAIN: 817.380.5110 tbpels #10194323 www.PERC-eng.com

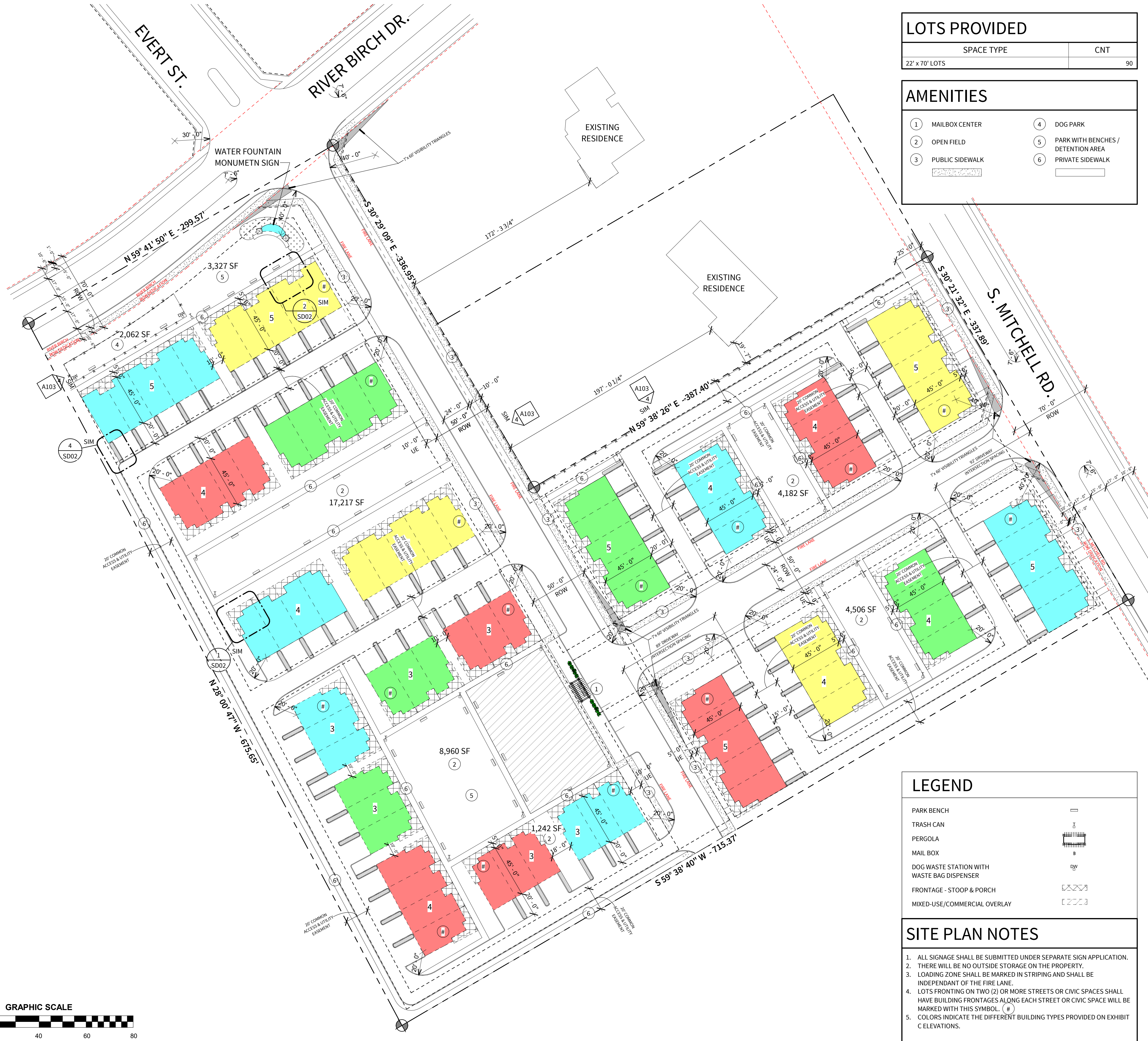

LOTS PROVIDED	
SPACE TYPE	CNT
22' x 70' LOTS	90

AMENITIES	
1 MAILBOX CENTER	4 DOG PARK
2 OPEN FIELD	5 PARK WITH BENCHES / DETENTION AREA
3 PUBLIC SIDEWALK	6 PRIVATE SIDEWALK

LEVEL 5

Level 5 Architecture
Mansfield, TX | Springdale, AR
level5architecture.com

THESE DOCUMENTS ARE FOR REVIEW ONLY AND ARE NOT INTENDED FOR CONSTRUCTION PURPOSES

ARCHITECT:
JUSTIN S. GILMORE
LEVEL 5 ARCHITECTURE

PROJECT INFORMATION:
SOUTH MITCHELL DEVELOPMENT

TOWNHOMES

SOUTH MITCHELL ROAD & RIVER BIRCH DRIVE, MANSFIELD, TX 76063

PROJECT NUMBER: 21-96T
ISSUE DATE: MM/DD/YYYY
REVISIONS:

ZC#23-006

SHEET NAME:
EXHIBIT B

SHEET NUMBER:
SD01

GRAPHIC SCALE

1 SITE PLAN
SCALE: 1" = 40'-0"

LEGEND	
PARK BENCH	
TRASH CAN	
PERGOLA	
MAIL BOX	
DOG WASTE STATION WITH WASTE BAG DISPENSER	
FRONTAGE - STOOP & PORCH	
MIXED-USE/COMMERCIAL OVERLAY	

- SITE PLAN NOTES**
- ALL SIGNAGE SHALL BE SUBMITTED UNDER SEPARATE SIGN APPLICATION.
 - THERE WILL BE NO OUTSIDE STORAGE ON THE PROPERTY.
 - LOADING ZONE SHALL BE MARKED IN STRIPING AND SHALL BE INDEPENDANT OF THE FIRE LANE.
 - LOTS FRONTING ON TWO (2) OR MORE STREETS OR CIVIC SPACES SHALL HAVE BUILDING FRONTAGES ALONG EACH STREET OR CIVIC SPACE WILL BE MARKED WITH THIS SYMBOL. (#)
 - COLORS INDICATE THE DIFFERENT BUILDING TYPES PROVIDED ON EXHIBIT C ELEVATIONS.

COPYRIGHT © 2022, LEVEL 5 ARCHITECTURE. THESE DOCUMENTS ARE PROPERTY OF THE ARCHITECT AND ARE ISSUED IN STRICT CONFIDENCE & SHALL NOT BE MADE AVAILABLE, REPRODUCED, COPIED, USED FOR ANY OTHER INTENDED PURPOSES, OR AS BASIS FOR MANUFACTURE OR SALE OF APPARATUS WITHOUT WRITTEN PERMISSION. COPYRIGHT © 2022, LEVEL 5 ARCHITECTURE.

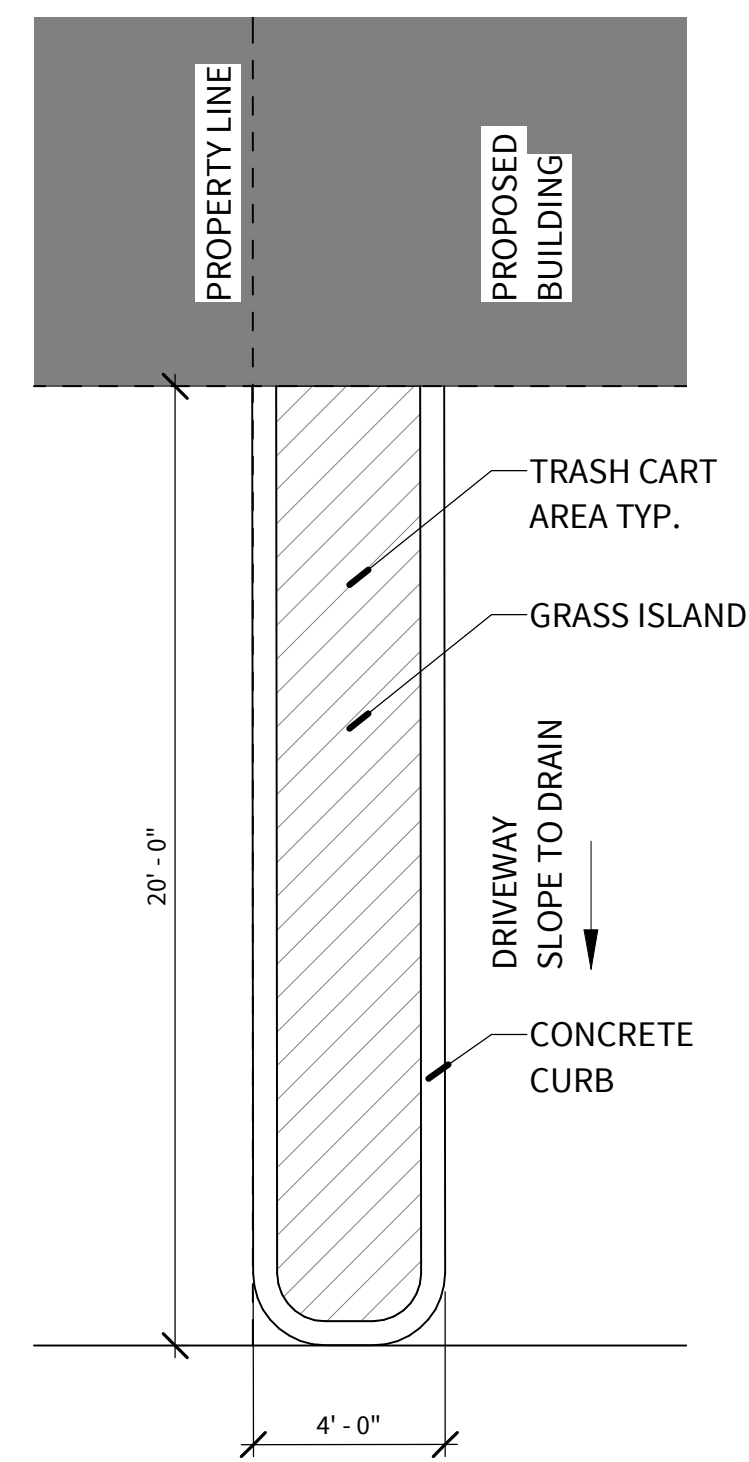

④ ENLARGED SITE PLAN
SCALE: 1/4" = 1'-0"

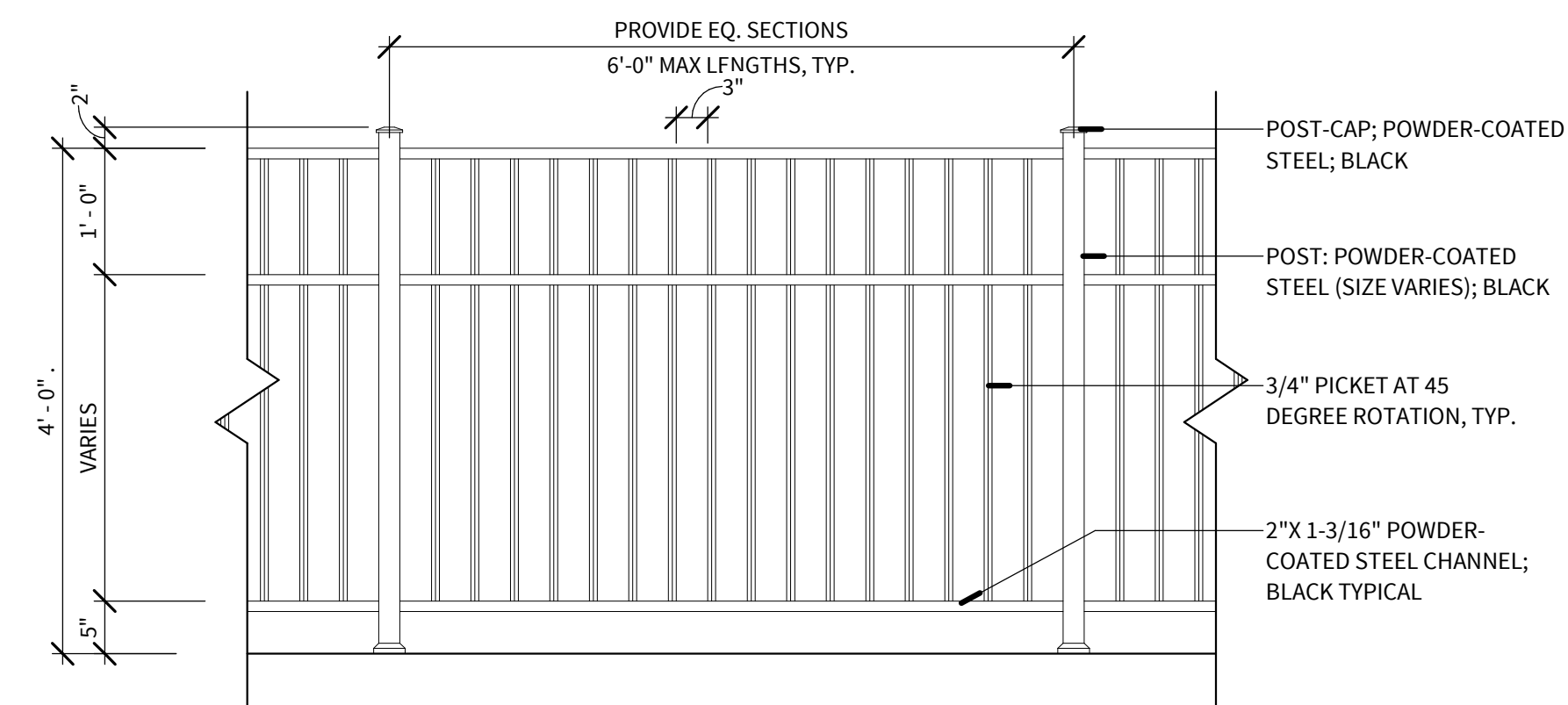

③ WROUGHT IRON RAILING ELEVATION
SCALE: 3/4" = 1'-0"

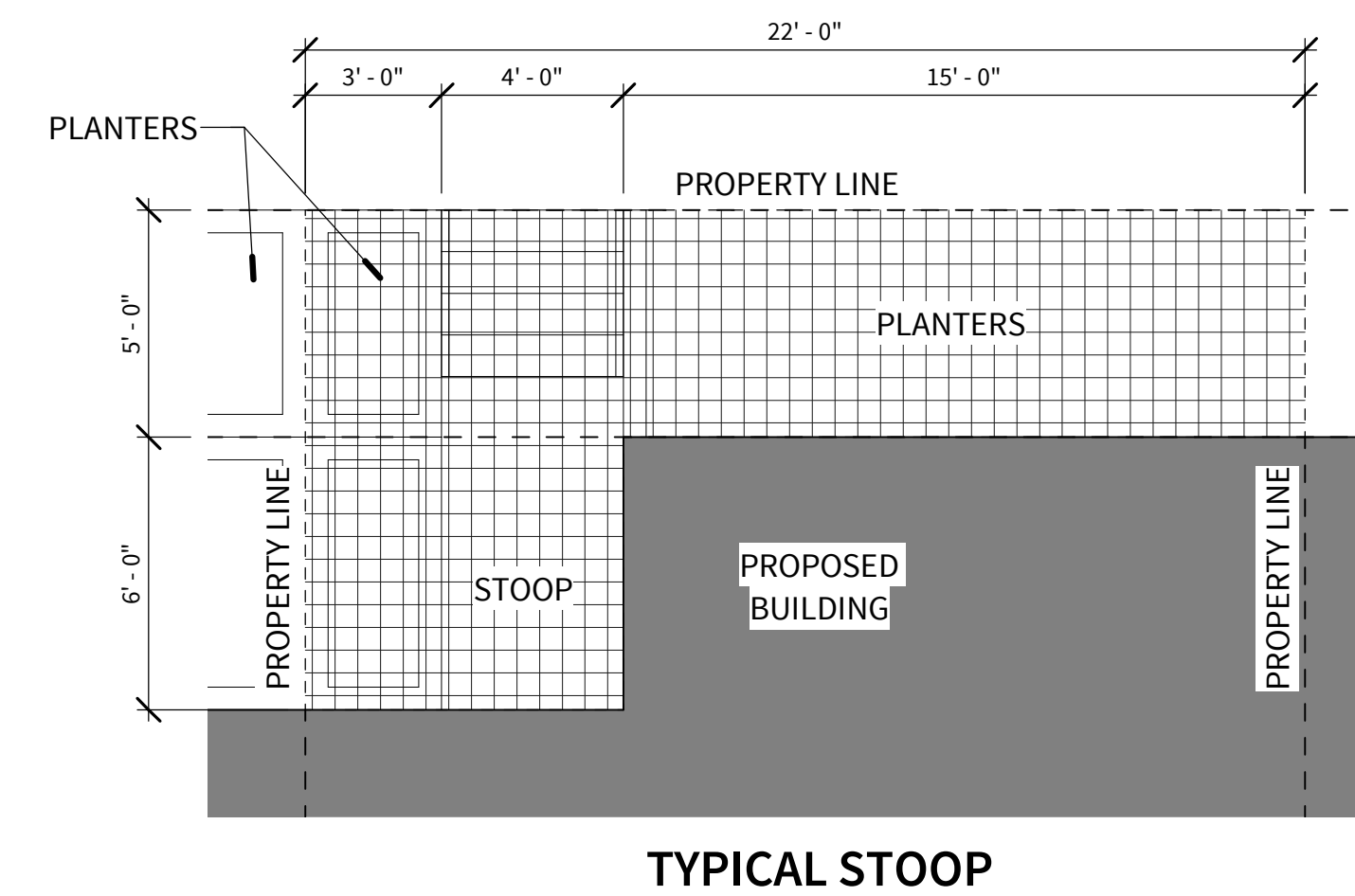

② ENLARGED SITE PLAN
SCALE: 1/4" = 1'-0"

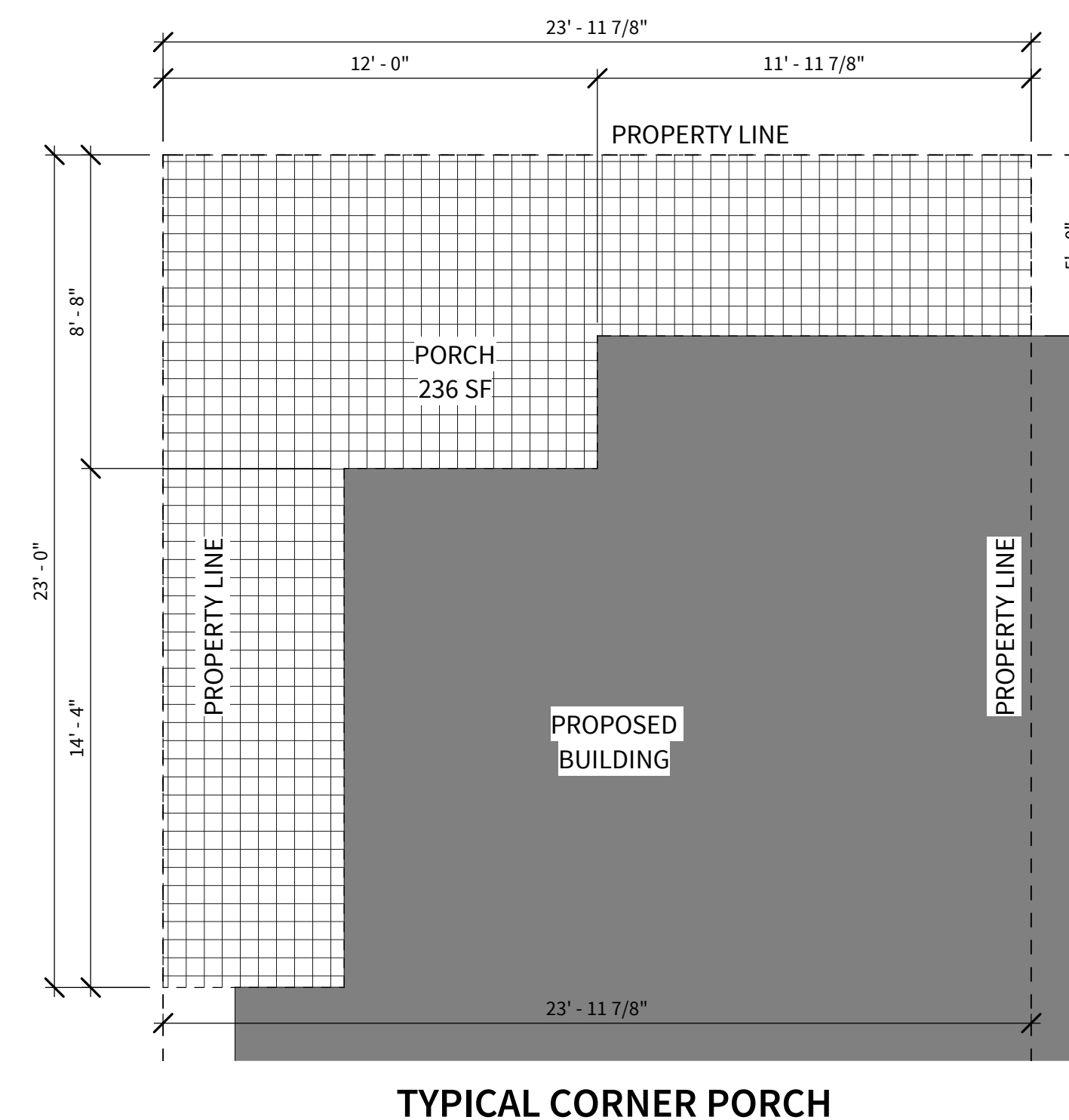

① ENLARGED SITE PLAN
SCALE: 1/4" = 1'-0"

LEVEL 5
Level 5 Architecture
Mansfield, TX | Springdale, AR
level5architecture.com

THESE DOCUMENTS ARE FOR REVIEW ONLY AND ARE NOT INTENDED FOR CONSTRUCTION PURPOSES
ARCHITECT: JUSTIN S. GILMORE
LEVEL 5 ARCHITECTURE

PROJECT INFORMATION:
SOUTH MITCHELL DEVELOPMENT

TOWNHOMES

SOUTH MITCHELL ROAD & RIVER BIRCH DRIVE, MANSFIELD, TX 76063

PROJECT NUMBER: 21-96T
ISSUE DATE: MM/DD/YYYY
REVISIONS:
ZC#23-006

SHEET NAME:
EXHIBIT B

SHEET NUMBER:
SD02
10/17/2023 4:12:50 PM

COPYRIGHT © 2022, LEVEL 5 ARCHITECTURE. EXCEPT AS MAY BE OTHERWISE PROVIDED, THESE DRAWINGS & SPECIFICATIONS ARE PROPERTY OF THE ARCHITECT AND ARE ISSUED IN STRICT CONFIDENCE & SHALL NOT BE MADE AVAILABLE, REPRODUCED, COPIED, USED FOR ANY OTHER INTENDED PURPOSES, OR AS BASIS FOR MANUFACTURE OR SALE OF APPARATUS WITHOUT WRITTEN PERMISSION. COPYRIGHT © 2022, LEVEL 5 ARCHITECTURE

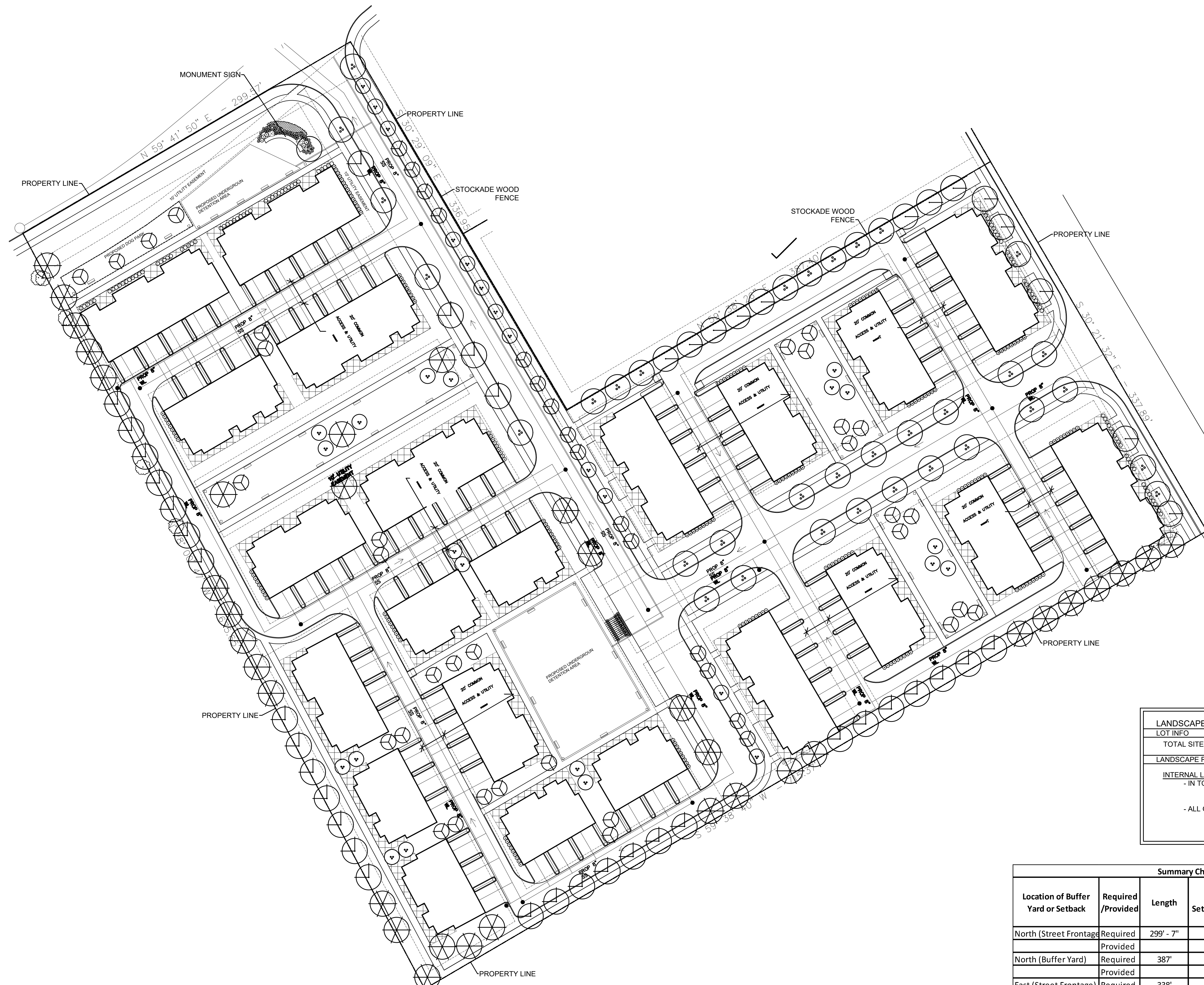

LANDSCAPE REQUIREMENTS

LOT INFO
 TOTAL SITE AREA: 7.87 AC (342,800 S.F.)

LANDSCAPE REQUIREMENTS

INTERNAL LANDSCAPE REQUIREMENTS:
 - IN TOWNHOUSE DEVELOPMENTS EVERGREEN SHRUBS ARE REQUIRED ALONG A MINIMUM OF 50% OF A BUILDING FACING A STREET FRONTAGE.
 - ALL GROUND EQUIPMENT TO BE SCREENED BY EVERGREEN SHRUBS.

Summary Chart - Buffer Yards/Setbacks							
Location of Buffer Yard or Setback	Required /Provided	Length	Bufferyard or Setback Width/Type	Canopy Trees	Ornamental Trees	Shrubs	Screening Wall/Device Height & Material
North (Street Frontage)	Required	299' - 7"	25' Setback	7.5			
	Provided		25'+ Setback	0			
North (Buffer Yard)	Required	387'	BY10	15.5			SW6
	Provided		BY10	16			SW6
East (Street Frontage)	Required	338'	25' Setback	8.5			
	Provided		25'+ Setback	9			
East (Buffer Yard)	Required	337'	BY10		14		SW6
	Provided		5' Setback		14		SW6
South	Required	715'	BY10	28.6			
	Provided		BY10	29			
West	Required	675'	BY10	27			
	Provided		BY10	27			

1 LANDSCAPE PLAN

SCALE: 1" = 40'-0"

0 40 80
 GRAPHIC SCALE IN FEET

N

ISSUES:

10-12-23	SITE PLAN SUBMITTAL

REVISIONS:

CLIENT:
 LEVEL 5 DESIGN GROUP
 501 E. Broad Street
 Mansfield, Texas 76063

SOUTH MITCHELL DEVELOPMENT

MANSFIELD, TEXAS

mgt
 landscape architects

MEEKS DESIGN GROUP, INC.
 1765 N. COLLINS BLVD., SUITE 300
 RICHARDSON, TX 75080
 PH (972) 690-7474
 F (972) 690-7878

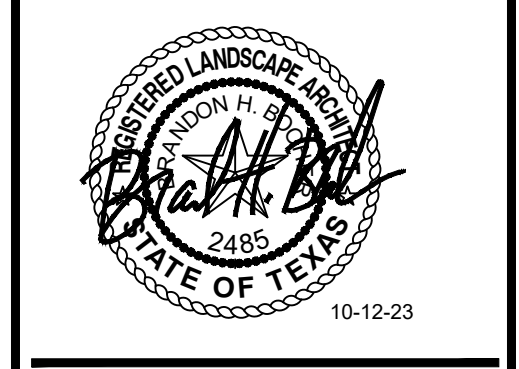

ZC#23-006

EXHIBIT D

MANSFIELD, TEXAS

JOB NUMBER: LEV-2201



TREE STAKE SOLUTIONS, LLC.
 9973 FM 521 Road Phone: 281-778-1400
 Rosharon, Texas 77583 Mobile: 903-676-6143
 www.treestakesolutions.com Fax: 281-778-1425

NOTES:

1. INSTALLATION TO BE COMPLETED IN ACCORDANCE WITH MANUFACTURER'S SPECIFICATIONS.
2. DO NOT SCALE DRAWING.
3. THIS DRAWING IS INTENDED FOR USE BY ARCHITECTS, ENGINEERS, CONTRACTORS, CONSULTANTS AND DESIGN PROFESSIONALS FOR PLANNING PURPOSES ONLY. THIS DRAWING MAY NOT BE USED FOR CONSTRUCTION.
4. ALL INFORMATION CONTAINED HEREIN WAS CURRENT AT THE TIME OF DEVELOPMENT BUT MUST BE REVIEWED AND APPROVED BY THE PRODUCT MANUFACTURER TO BE CONSIDERED ACCURATE.
5. CONTRACTOR'S NOTE: FOR PRODUCT AND COMPANY INFORMATION VISIT www.treestakesolutions.com

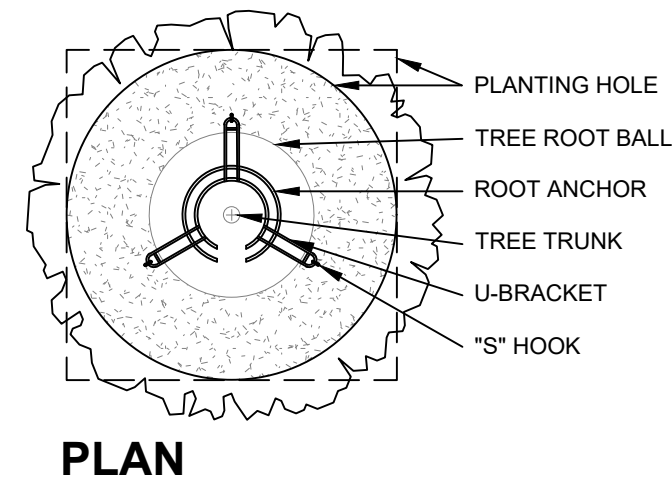

PLAN

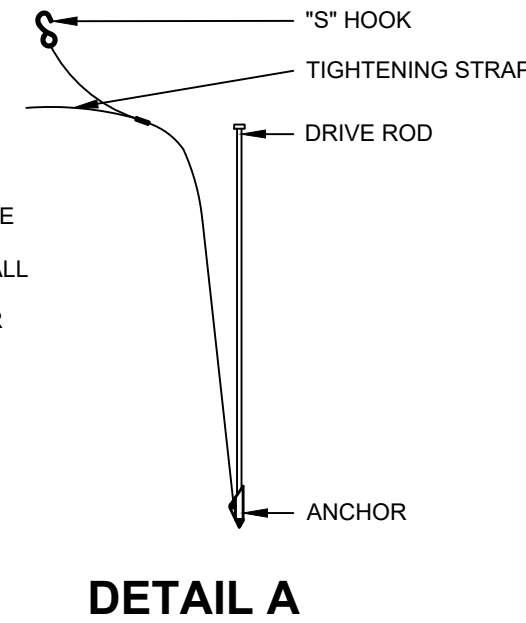

DETAIL A

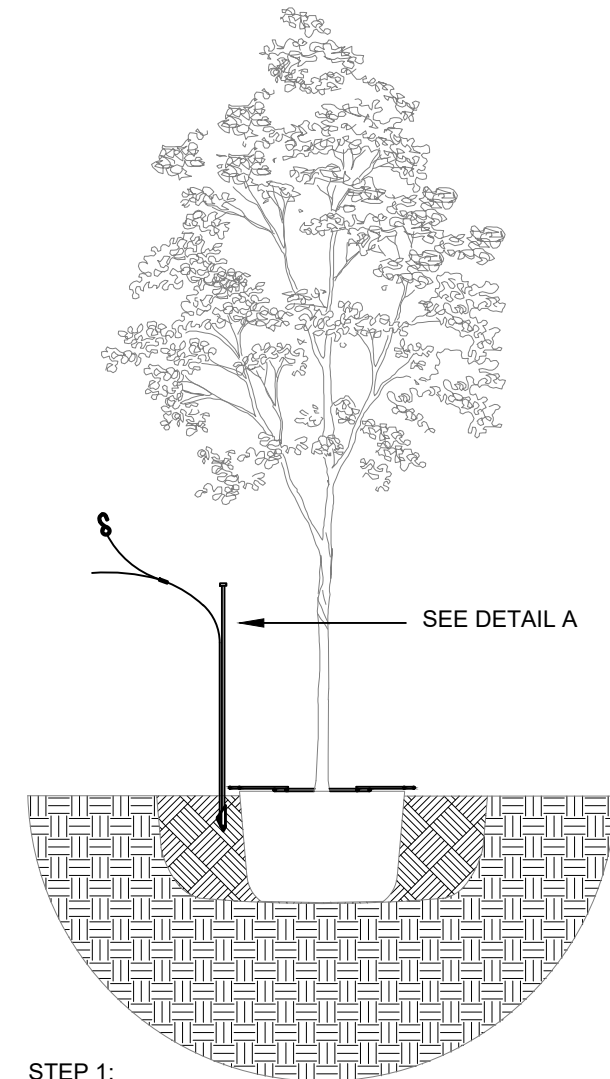

STEP 1:

- SET TREE IN PLANTING PIT
- PLACE ANCHOR WITH RING SIDE DOWN AGAINST TOP OF ROOTBALL
- CENTER ROOT ANCHOR'S INNER RING(S) AROUND TRUNK OF TREE
- ALIGN DRIVE ROD AS CLOSE AS POSSIBLE TO OUTSIDE EDGE OF U-BRACKET



STEP 2:

- DRIVE ANCHOR STRAIGHT DOWN INTO UNDISTURBED SUBBASE SOIL TO RECOMMENDED DEPTH AS PER TREE SIZING CHART BELOW

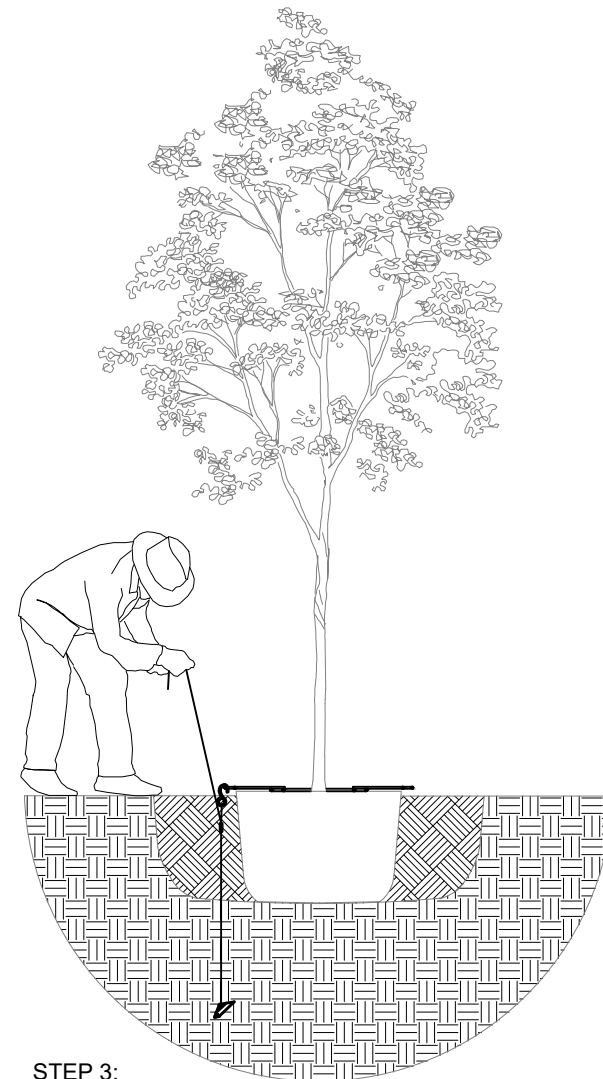

STEP 3:

- REMOVE DRIVE ROD
- REPEAT STEPS 1 & 2 FOR ALL THREE (3) ANCHOR LOCATIONS
- PULL BACK ON STRAP APPROXIMATELY 3" FOR THE V-88 ANCHOR, OR 6" TO 7" FOR THE V-88 ANCHOR TO SET ANCHOR INTO A HORIZONTAL OR LOCKED POSITION. A FULCRUM MAY BE REQUIRED TO ASSIST IN SETTING THE ANCHOR.
- PLACE "S" HOOK OVER THE END OF THE U-BRACKET
- PULL STRAP(S) UP VERTICALLY UNTIL ROOT ANCHOR RINGS BITE INTO THE TOP OF THE ROOT BALL AND U-BRACKETS ARE SETTING FLUSH ON TOP OF THE ROOT BALL
- TIE EXCESS STRAPS OFF TO THE U-BRACKET ALLOWING ENOUGH REMAINING STRAP TO ADJUST TREE, IF NECESSARY

1 TREE PLANTING DETAILS NTS

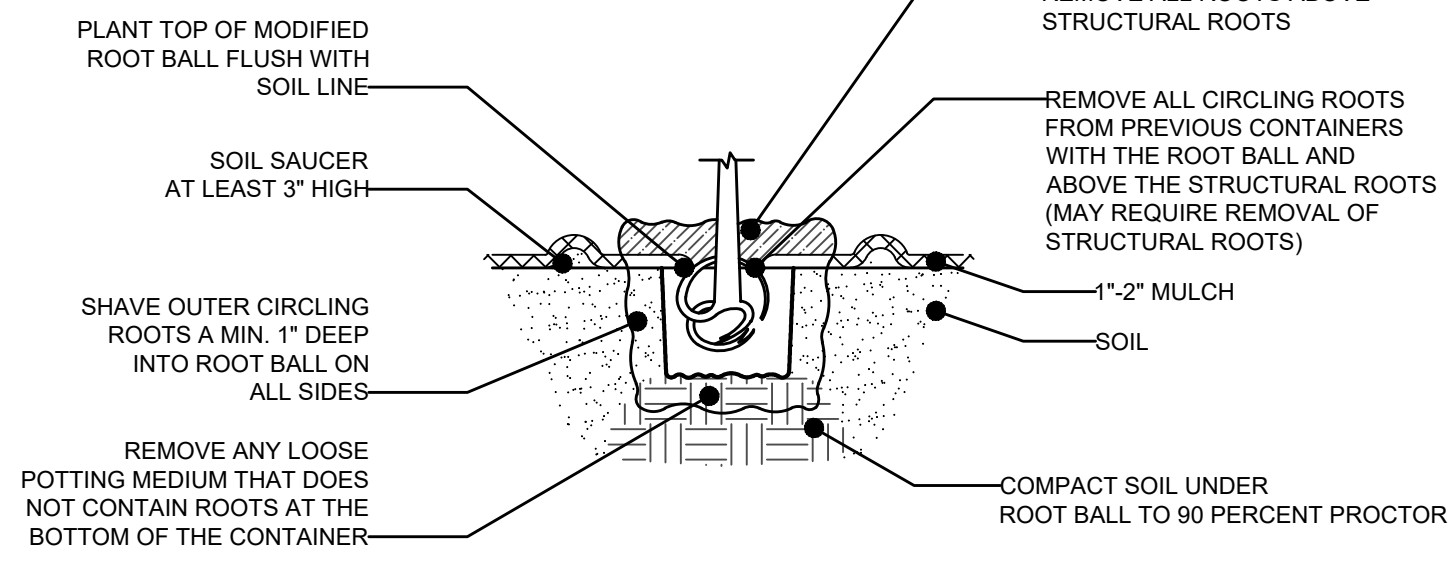

2 CONTAINER GROWN TREE DETAIL NTS

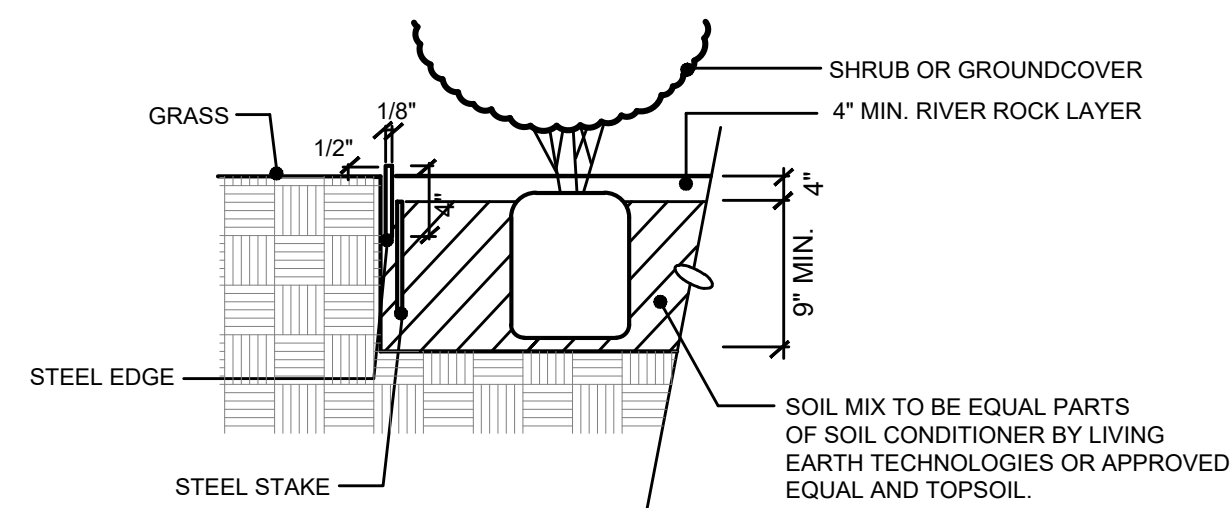

3 BED-PREP WITH STEEL EDGE NTS

LANDSCAPING NOTES

1. ALL PLANT MATERIAL SHALL MEET THE LATEST REQUIREMENTS OF THE AMERICAN STANDARD FOR NURSERY STOCK (ANSI Z60.1).
2. ALL NEW PLANT MATERIAL SHALL BE PLANTED AND MAINTAINED IN ACCORDANCE WITH THE LATEST EDITION OF THE AMERICAN NATIONAL STANDARDS INSTITUTE REQUIREMENTS FOR TREE, SHRUB, AND OTHER WOODY PLANT MAINTENANCE (ANSI A300 PARTS 1 THROUGH 6).
3. PROVIDE ADJUSTABLE BUBBLERS ON ALL TREES IN ORDER TO MEET THE SPECIFIC HYDROLOGIC REQUIREMENTS OF NEWLY PLANTED TREES IN ACCORDANCE WITH TCEQ.
4. DRIP EMITTERS (BUBBLERS) SHALL BE INSTALLED AT EACH TREE LOCATION AND OPERATE ON VALVES SEPARATE FROM THE SPRAY ZONES.
5. NO TREE SHALL BE PLANTED CLOSER THAN 5 FEET FROM ANY UNDERGROUND PUBLIC WATER AND WASTEWATER LINE.
6. NO TREE SHALL BE PLANTED CLOSER THAN 4 FEET FROM IMPERVIOUS COVER.
7. FENCES, LANDSCAPING AND OTHER ITEMS WILL NOT BE INSTALLED IN LOCATIONS WHERE THEY WILL OBSTRUCT THE VISIBILITY OF, OR ACCESS TO, FIRE HYDRANTS OR FIRE DEPARTMENT CONNECTIONS (FDC).

PLANT LEGEND

SYM	BOTANICAL NAME	COMMON NAME	QUAN	SIZE	REMARKS
SHADE TREES					
CE	Ulmus crassifolia	Cedar Elm	35	3.5" Cal. min.	10'-12' HT
BO	Quercus virginiana	Bur Oak	13	3.5" Cal. min.	10'-12' HT
LO	Quercus virginiana	Live Oak	35	3.5" Cal. min.	10'-12' HT
TA	Fraxinus texensis	Texas Ash	32	3.5" Cal. min.	10'-12' HT
ORNAMENTAL TREES					
CM	Lagerstroemia indica 'Natchez'	Crepe Myrtle 'Natchez'	31	8'-10' HT	Multi-trunk, 3-5 canes, min. 1" cal. Per cane
YH	Ilex Vomitoria	Yaupon Holly	48	8'-10' HT	Multi-trunk, 3-5 canes, min. 1" cal. Per cane
SHRUBS					
AS	Salvia greggii	Autumn Sage	25	3 Gal.	24" min. ht, 18" min. spread
AB	Abelia x grandiflora	Glossy Abelia	102	3 Gal.	24" min. ht, 18" min. spread
MG	Miscanthus sinensis	Maiden Grass	19	3 Gal.	24" min. ht, 18" min. spread
PD	Loropetalum sinense	Loropetalum	6	3 Gal.	24" min. ht, 18" min. spread
TS	Leucophyllum frutescens	Texas Sage	195	3 Gal.	24" min. ht, 18" min. spread
GROUNDCOVER					
SC		Seasonal Color	180	4" Pots	
SS	Cynodon spp.	Tifway 419 Bermuda			Solid Sod

TYPICAL PLANTING NOTES

1. ALL PLANT MATERIAL LOCATIONS SHALL BE STAKED IN THE FIELD BY THE CONTRACTOR AND APPROVED BY THE OWNER / LANDSCAPE ARCHITECT PRIOR TO INSTALLATION.
2. FINE GRADING SHALL BE PERFORMED IN ALL AREAS TO BE SEEDED/SODDED. FINE GRADING SHALL INCLUDE THE REMOVAL OF DEBRIS, ROCKS, ETC. FROM THE SITES AND INSURE POSITIVE DRAINAGE IN ALL AREAS SEEDED/SODDED.
3. THE CONTRACTOR SHALL VERIFY ALL BUILDING SETBACK LINES, EASEMENT LINES, AND VISIBILITY LINES IN THE FIELD PRIOR TO CONSTRUCTION.
4. THE CONTRACTOR SHALL VERIFY LOCATIONS OF ALL UTILITIES, SHOWN ON THIS PLAN AND NOT SHOWN ON THESE PLANS, IN THE FIELD PRIOR TO COMMENCEMENT OF WORK.
5. PROVIDE POSITIVE DRAINAGE AWAY FROM ALL SITE FEATURES.
6. STEEL EDGING SHALL BE INSTALLED AT ALL LOCATIONS WHERE PLANT MATERIALS MEET TURF AREAS.

CONTRACTOR IS RESPONSIBLE FOR ALL PLANT MATERIAL SHOWN ON PLANTING PLANS. THE PLANT LIST IS TO BE USED FOR PLANT NAMES, SYMBOLS, SIZES AND SPACING. QUANTITIES SHOWN ARE FOR COMPARISON AND SHOULD ONLY BE USED FOR BIDDING OR PRICE QUOTES.

1 PLANT LIST AND DETAILS

ISSUES:

10-12-23	SITE PLAN SUBMITTAL

REVISIONS:

CLIENT:
 LEVEL 5 DESIGN GROUP
 501 E. Broad Street
 Mansfield, Texas 76063

SOUTH MITCHELL DEVELOPMENT
 MANSFIELD, TEXAS

mgb
 landscape architects
 MEEKS DESIGN GROUP, INC.
 1755 N. COLLINS BLVD., SUITE 300
 RICHARDSON, TX 75080
 PH (972) 690-7474
 F (972) 690-7878



ZC#23-006
 EXHIBIT D
 MANSFIELD, TEXAS
 JOB NUMBER: LEV-2201

PLANT LIST AND DETAILS

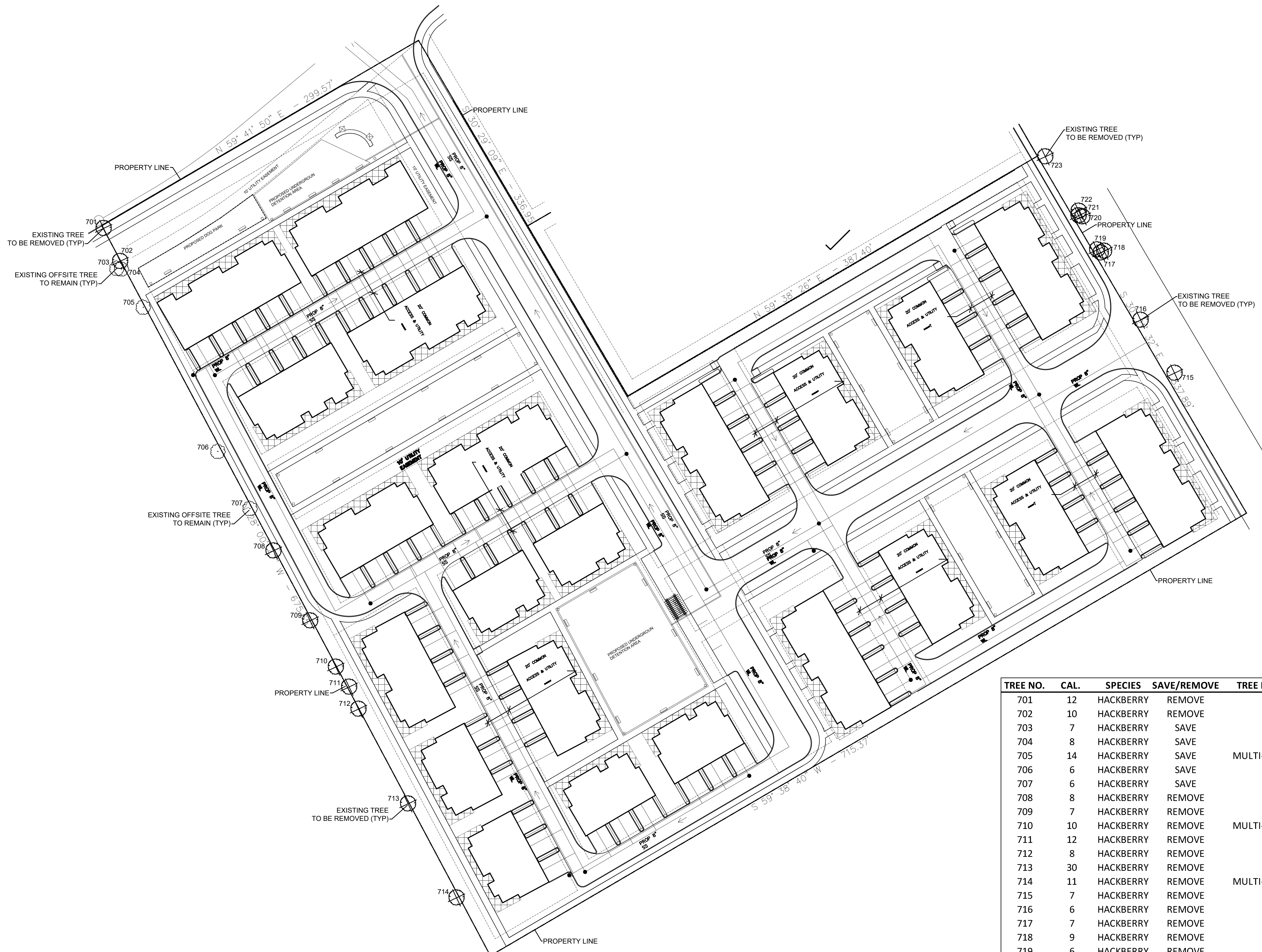

TREE NO.	CAL.	SPECIES	SAVE/REMOVE	TREE NOTES	NOTES	MITIGATION
701	12	HACKBERRY	REMOVE			12
702	10	HACKBERRY	REMOVE			10
703	7	HACKBERRY	SAVE		OFFSITE	
704	8	HACKBERRY	SAVE		OFFSITE	
705	14	HACKBERRY	SAVE	MULTI-TRUNK	OFFSITE	
706	6	HACKBERRY	SAVE		OFFSITE	
707	6	HACKBERRY	SAVE		OFFSITE	
708	8	HACKBERRY	REMOVE			8
709	7	HACKBERRY	REMOVE			7
710	10	HACKBERRY	REMOVE	MULTI-TRUNK		10
711	12	HACKBERRY	REMOVE			12
712	8	HACKBERRY	REMOVE			8
713	30	HACKBERRY	REMOVE			30
714	11	HACKBERRY	REMOVE	MULTI-TRUNK		11
715	7	HACKBERRY	REMOVE		ROW EXEMPT	
716	6	HACKBERRY	REMOVE		ROW EXEMPT	
717	7	HACKBERRY	REMOVE		ROW EXEMPT	
718	9	HACKBERRY	REMOVE		ROW EXEMPT	
719	6	HACKBERRY	REMOVE		ROW EXEMPT	
720	6	HACKBERRY	REMOVE		ROW EXEMPT	
721	7	HACKBERRY	REMOVE		ROW EXEMPT	
722	7	HACKBERRY	REMOVE		ROW EXEMPT	
723	11	HACKBERRY	REMOVE	MULTI-TRUNK	ROW EXEMPT	
	215					108

1 TREE PRESERVATION PLAN
SCALE: 1" = 40'-0"

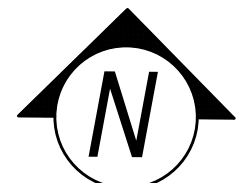
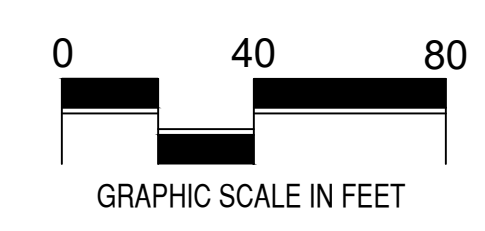

ISSUES:

10-12-23	SITE PLAN SUBMITTAL

REVISIONS:

CLIENT:
LEVEL 5 DESIGN GROUP
501 E. Broad Street
Mansfield, Texas 76063

SOUTH MITCHELL DEVELOPMENT
MANSFIELD, TEXAS

mgt landscape architects
MECKS DESIGN GROUP, INC.
1755 N. COLLINS BLVD., SUITE 300
RICHARDSON, TX 75080
PH (972) 690-7474
F (972) 690-7878

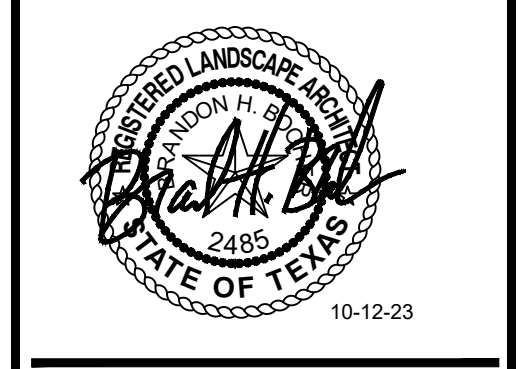

ZC#23-006
EXHIBIT D
MANSFIELD, TEXAS
JOB NUMBER: LEV-2201

TREE PRESERVATION PLAN

EXHIBIT E FOR ZC#23-006

DREAMSVILLE MANSFIELD, PLANNED DEVELOPMENT DISTRICT REGULATIONS

PURPOSE AND INTENT:

The purpose and the intent of this Dreamsville Mansfield Planned Development District (this “PD, PLANNED DEVELOPMENT DISTRICT”), is to provide a distinct set of regulations that will produce a new housing community on an infill parcel of land for a multi-generational development that is not only aesthetically pleasing in all aspects, but carries an efficient use of infill development.

APPLICABILITY:

- A. All proposed development shall be in accordance with the provisions of this PD, PLANNED DEVELOPMENT DISTRICT, and development plans recorded hereunder, if any, shall be binding upon the applicant thereof, his and all successors and assigns, and shall limit and control all applications for building permits.
- B. The provisions of Chapter 155 of the Mansfield Code of Ordinances (Zoning Ordinance) shall continue to be applicable to all issues not covered by the regulations found in this PD, PLANNED DEVELOPMENT DISTRICT.
- C. In the event of a conflict between these PD, PLANNED DEVELOPMENT DISTRICT standards and the Zoning Ordinance, as amended, the standards that are set forth herein shall prevail.
- D. In the event of a conflict between these PD, PLANNED DEVELOPMENT DISTRICT standards and any of its illustrations, photographs, and other exhibits, including the site

plan, that are attached thereto, and that are specified elsewhere in text, the standards that are set forth herein in the text shall prevail.

- E. In the event of a conflict between these PD, PLANNED DEVELOPMENT DISTRICT standards and any other codes, ordinances, regulations, or standards as adopted by the City of Mansfield, Texas, the standards that are set forth herein shall prevail.
- F. The appeals process for this PD, PLANNED DEVELOPMENT DISTRICT, follows the considerations and procedures as set forth in Section 155.066 of the Mansfield Zoning Ordinance.

DESCRIPTIONS OF DEVELOPMENT TRACT:

Development pursuant to the provisions of this PD, PLANNED DEVELOPMENT DISTRICT, is regulated in accordance with the intensity of the residential uses permitted, according to the following legally described tract:

- A. DEVELOPMENT TRACT OF LAND LOCATED IN THE SAMUEL MITCHELL SURVEY, ABSTRACT NO. 593 (EXHIBIT “A”).

DEVELOPMENT PLAN:

For the purpose of this PD, PLANNED DEVELOPMENT DISTRICT, a site plan and illustrative renderings of the dwelling unit types are attached hereto, respectively, as “EXHIBIT B - SD01” (collectively the “DEVELOPMENT PLAN”) to achieve the following:

- A. To establish all required setbacks and buffers for the property in the locations identified on the Development Plan; and

- B. To identify the uses of the dwelling units and clarify business applications within the dwelling units.

DEFINITIONS:

The following provides definitions for terms used in this PD, PLANNED DEVELOPMENT DISTRICT, that are technical in nature or otherwise may not reflect a common usage of the term.

Where terms are not defined in this PD, PLANNED DEVELOPMENT DISTRICT, and are defined in Section 155.012 of the Mansfield Code of Ordinances, such terms shall have the meanings ascribed to them as found in that Section. Where terms are not defined in this PD, PLANNED DEVELOPMENT DISTRICT or in Section 155.012 of the Mansfield Code of Ordinances, such terms shall have ordinarily accepted meanings such as the context applies.

ANCILLARY ROOF: A secondary structure attached to the principal structure, typically in the form of a one-story structure attached to a two-story structure.

ARCH: A curved symmetrical structure spanning an opening and typically supporting the weight of a bridge, roof, or wall above it.

ATTIC: The interior part of a building contained within a pitched roof structure.

AWNING: A fixed or movable shading structure, and cantilevered or otherwise entirely supported from a building, used to protect outdoor spaces from sun, rain, and other natural conditions.

BROWNSTONE: A single-family dwelling that shares a party wall with another of the same type and it occupies the full width of the front lot line (SYNONYM: ROW HOUSE, SINGLE-FAMILY ATTACHED).

BUILDING ELEVATION: An exterior wall of a building.

BUILDING FRONTAGE: The area between a building elevation and the public right-of-way, it is inclusive of its built and planted components.

BUILDING HEIGHT: The vertical extent of a building measured in stories.

CORNER MARKET: A single small-scale retail business, that may be standalone or a part of a mixed-use building, typically supplying a limited selection of fresh or preserved food and sundries. It may or it may not be reinforced by a food service establishment or a mail center (SYNONYM: CORNER STORE).

DRIVEWAY: A vehicular lane within a lot, often leading to a garage.

DOORYARD FRONTAGE: A building frontage type with a shallow setback and a front garden or a patio, usually with a low wall or hedge at the lot line, minimum of 3'-0" (VARIANT: LIGHTWELL, LIGHT COURT).

GLAZING: The portion of a building elevation that is comprised of transparent glass, and that is usually set in doors and windows.

LIVE-WORK: A mixed use building consisting of a commercial component and a residential component. The commercial component is restricted to the first story. It is intended to be occupied by a business operator who lives in the same building that contains the commercial activity.

LOT: A parcel of land accommodating a building or buildings under single ownership.

LOT COVERAGE: The percentage of any lot that may be covered by buildings and other roofed structures.

LOT LINE: The boundary that legally and geometrically demarcates a lot.

PIER: A solid support that is designed to sustain vertical pressure.

PORCH: An open-air room appended to a building, with floor and roof, but no walls on at least two (2) sides. Typical porch provided on sheet “EXHIBIT B - SD01”. Minimum depth is 5’-0” and width of 10’-0”.

PRINCIPAL ENTRANCE: The main point of access for pedestrians into a building.

REAR ALLEY: a private right-of-way, or access easement, designated to be a secondary means of vehicular access to the rear or to the side of lots; a rear alley may connect to a vehicular driveway located to the rear of lots providing access to accessory buildings, service areas, and parking, and may contain utility easements.

STOOP FRONTAGE: A building frontage wherein the building elevation is aligned close to the front lot line with the first story elevated from the sidewalk for privacy, and with an exterior stair and a landing at an entrance. Typical stoop provided on sheet “EXHIBIT B - SD01”

STORY: A habitable level within a building, excluding an attic or a raised basement.

GENERAL SITE AND BUILDING STANDARDS:

A. CONSIDERATIONS FOR UTILITIES.

1. Utilities shall be placed underground.
2. Utility services may require easements at the front, side, or rear lot lines for meters, pedestals, and other equipment requirements.

B. CONSIDERATIONS FOR LANDSCAPING.

1. All landscaping plans shall require approval by the Director of Planning.

2. All topographic transitions between improvements and existing grades or between lots shall appear to be natural slopes or to be garden terraces. In the event natural slopes or garden terraces are not possible, retaining walls may be used, at a maximum height of 2'-09, subject to review and approval by the Director of Planning.
3. All removal of trees larger than six (6) inches caliper shall require approval by the Director of Planning.

C. CONSIDERATIONS FOR LIGHTING.

1. Exterior light fixtures shall be compatible with the architectural style of the building to which they are attached.
 - a. Uplighting, floodlighting, and wall washing lighting shall be prohibited.
2. Garage doors opening onto a rear alley shall provide a light fixture with a photocell that lights from dusk to dawn.

SITE AND BUILDING STANDARDS SPECIFIC TO SINGLE-FAMILY ATTACHED (BROWNSTONES):

The site and building standards provided below shall be specific to construction the legally described property in “EXHIBIT A” and intended to allow only for single-family attached residential uses (i.e., brownstones) situated on individually platted lots.

- A. PERMITTED USES. Permitted uses of brownstones and lots shall be limited to allowable uses provided below, except where modified by the COMMERCIAL / MIXED-USE OVERLAY DISTRICT standards as set forth in this PD, PLANNED

DEVELOPMENT DISTRICT.

1. The uses permitted for lots shall be expressly limited to the following:
 - a. Brownstone.
 - b. Home Occupation.

B. LOT ORIENTATION.

1. All lots shall front on a street or a civic space.
2. All lots shall be accessed from a rear alley.

C. LOT SIZE AND LOT OCCUPATION.

1. The minimum lot size shall be a minimum of 1,800 square feet.
 - a. The minimum lot width shall be 22 feet.
 - b. The minimum lot depth shall be 80 feet.
 - c. The minimum lot frontage shall be 20 feet.
2. The maximum lot coverage for all principal buildings and their accessory buildings shall not exceed 70 percent.
3. The minimum habitable area for a principal building shall be 1,500 square feet of enclosed space, not including garages, patios, and porches.

D. BUILDING SETBACKS.

1. General:
 - a. Only one (1) principal dwelling unit may be built on each lot
2. Principal Buildings:

- a. Minimum front yard — 5 feet.
- b. Minimum side yard — 0 feet.
- c. Minimum rear yard — 5 feet.

3. Accessory buildings.

- a. Applicable regulations and restrictions for accessory building setbacks per Section 155.099 of the Mansfield Code of Ordinances shall apply.

E. BUILDING HEIGHT.

1. General:

- a. Building height is limited by stories and is measured from highest adjacent sidewalk grade. Stories shall not exceed more than 14 feet in height.
- b. Building height shall be measured from finished floor to finished ceiling.
- c. Below grade stories do not count towards height calculations, provided they do not extend more than four (4) feet above the sidewalk grade.
- d. Chimneys, cupulas, antennae, vents, elevator bulkheads, stair housing, and other uninhabited elements do not count towards building height.

2. Principal buildings.

- a. Principal buildings shall have a minimum height of three (3) stories and be limited to a maximum height of three and a half (3.5) stories.
- b. Principal buildings shall have a minimum ceiling height of ten (10) feet at the first story.

F. BUILDING FRONTAGES.

1. General:
 - a. Lots fronting on two (2) or more streets or civic spaces shall have building frontages along each street or civic space (i.e., Identified on Site Plan Notes on sheet “EXHIBIT B – SD01”).
 - b. Balconies, bay windows, and such are permitted to encroach into the front setback up to 100 percent of its depth.
 - c. In order to encourage diversity in design, building frontages shall vary lot to lot.
 - d. All brownstones shall provide a dooryard frontage or a stoop frontage.
2. Dooryard frontages:
 - a. Dooryards may be raised a minimum of two (2) feet from average sidewalk grade at the frontage.
 - b. Fences or walls shall be provided as a part of the dooryard.
 - c. All dooryards shall be no less than five (5) feet deep.
 - d. All dooryard fences and walls shall be four (4) feet in height.
 - e. All dooryards shall be bound by fences or walls on three (3) sides.
 - f. An evergreen hedge may replace a fence or wall.
 - g. Dooryards may be paved in brick, cobble, or stone.
3. Stoop frontages:
 - a. All stoops shall be no less than five (5) feet in depth.
 - b. All stoops shall be between four (4) and six (6) feet in width.
 - c. All stoops shall be covered by a pitched roof structure.
 - d. Stoops may encroach into the front setback up to 100 percent of its depth.

- e. Stoops may be recessed into the main volume of the brownstone where front setbacks are less than five (5) feet.

G. PARKING REQUIREMENTS.

1. General:

- a. A minimum of two (2) parking spaces shall be provided for each principal dwelling unit and located within a garage.
- b. Required parking shall be accessed from a rear alley and the required parking shall be oriented to the rear of the lot.
- c. All garages shall be configured in the following orientation, as generally described below:
 - (i) Rear-entry, within the principal dwelling unit volume; and
 - (ii) The garage shall be set toward the rear of the principal dwelling unit volume.

H. ARCHITECTURE.

1. General.

- a. The architectural design and inspiration for the brownstones shall generally be derived from PHOTOGRAPH NO. 1, PHOTOGRAPH NO. 2, and PHOTOGRAPH NO. 3 attached to this PD, PLANNED DEVELOPMENT DISTRICT. Block-based architecture diversity shall include special details to enhance the distinctiveness of each unit. This may include changes in color, material, height, entry portico, stoops,

railings, and other similar architectural features and elements. Site Plan located on sheet “EXHIBIT B – SD01” shows different colors to represent each block-based architecture units.

- b. There shall be no more than five (5) principal dwelling units attached under the same roof.

2. Walls.

- a. More than two (2) building wall materials shall be used on the exterior of a brownstone, excluding bay windows, patios, porches, exterior shutters, trim, and such.
- b. Building walls shall be finished in brick or stone. Cementitious fiber board, stucco, and wood can only be used as an accent material and where used on a single building, shall not exceed 20 percent of the total building wall area, with each building elevation being calculated independently.
 - (i) All stucco shall be masonry.
 - (ii) All stucco shall have a smooth sand finish.
 - (iii) All exposed exterior wood shall be painted or stained.
 - (iv) Exterior insulation and finish systems (E.I.F.S.) are prohibited.
- c. The heavier of the building wall materials shall be located below the light (e.g. stone below brick; brick below stucco; and stucco below cementitious fiber board and wood). The material transition shall run horizontally across the entire length of the building elevation.
- d. Arches and piers shall match the primary materials and the primary colors of the building walls and shall be no less than 12 inches by 12 inches.

- e. Columns shall be made of concrete or stone and shall be no less than 12 inches by 12 inches.
- f. Posts shall be made of wood or a synthetic material that has the appearance of wood.
 - (i) All posts shall be no less than six (6) inches by six (6) inches.
- g. All columns, piers, and posts shall be appropriately spaced in order to form square or vertically proportioned bays.

3. Roofs.

- a. Principal roofs, where sloped, shall be symmetrical gable or hip and angled no less than 6:12. Sloped roofs shall only be clad in asphalt shingle, slate, or terra cotta tile. Sloped roof cladding may include metal, provided that it complements an architectural style and that it minimizes glare.
- b. Principal roofs, where low-slope (i.e., flat), shall be surrounded on all sides by a horizontal parapet wall no less than three-and-a-half (3.5) feet in height where the roof deck meets the parapet wall.
- c. Ancillary roofs may be sheds angled no less than 3:12.

4. Openings.

- a. Principal dwelling units shall have a limit for door and window openings in building elevations that are set along a street or a civic space. No less than 15 percent and no more than 40 percent of the total building wall area shall be used for door and window openings.
 - (i) All windows openings shall be vertically proportioned and shall be

rectangular in shape where visible from streets and civic spaces.

(ii) All windows shall use vertically proportioned panes, excluding any transom windows above door openings visible from streets and civic spaces.

b. Door and window openings shall reveal their thickness within the building wall, and where appropriate to the building material that is used. Doors and windows in building walls made of brick, stone, and stucco shall be recessed a minimum of three (3) inches in depth.

c. Door and window header heights shall be consistent on building elevations fronting a street or a civic space.

d. Door and window openings in building elevations that are set along a street or a civic space shall be evenly spaced to create a harmonious composition.

e. Garage doors shall be made of wood or composite wood and may have glass or framed panels.

5. Attachments.

a. Chimneys, where visible, shall be clad in brick, stone, or stucco.

(i) All chimneys shall extend to the ground and shall have a projecting cap on top.

b. All flooring at stoops (e.g., the exterior stair and the landing) shall be made of brick, concrete, or stone to match the building wall finish.

c. All flooring at balconies and at porches shall be made of brick, concrete, or stone.

- d. Any part of a balcony projecting beyond a building wall shall be structurally supported by concrete beams or profiled sills or wood beams or brackets of appropriate scale.

I. STREETSCAPE STANDARDS.

1. Private streets shall be paved in concrete, and they may be paved in other surface materials including asphalt, brick, cobble, or stone subject to review and approval by the Director of Planning.
2. Private streets shall have street trees planted on center, every 30 feet.
3. The minimum sidewalk width shall be five (5) feet.
4. The minimum parkway width shall be four (4) feet.
5. Rear Alleys:
 - a. The minimum width of the access easement for an alley shall be 20 feet and shall have a minimum pavement width of 14 feet.

J. SITE PLAN.

1. Development shall require a site plan subject to review and approval by the Director of Planning. Such site plan shall be reviewed and approved prior to platting and the issuance of any building permit. The site plan shall be prepared and submitted to demonstrate compliance with all the provisions for development and all other applicable provisions of this PD, PLANNED DEVELOPMENT DISTRICT and the Mansfield Code of Ordinances.

COMMERCIAL / MIXED-USE OVERLAY DISTRICT:

Consistent with the recently adopted Mansfield 2040 Plan, the City of Mansfield, Texas (the “City”) understands and supports the need for neighborhood-centered retail and service uses which are typically found in walkable and mixed-use environments. The City understands and supports the need for neighborhood-oriented retail and service uses to ensure that most dwellings are within walking or cycling distance of the ordinary activities necessary for daily life. In order to accommodate neighborhood-oriented retail and service uses within this project, a “COMMERCIAL / MIXED-USE OVERLAY DISTRICT” shall be applied to certain lots within this planned development that may be appropriate for commercial activities as shown on “EXHIBIT B – SD-01”. It is understood that not all the lots within this PD, PLANNED DEVELOPMENT DISTRICT may need to be developed for neighborhood-oriented retail and service use due to conditions and preferences in the marketplace. It is further understood that nothing contained within this PD, PLANNED DEVELOPMENT DISTRICT, shall require the developer, or any property owner to develop, nurture, and sustain any commercial enterprise for lots located within the COMMERCIAL / MIXED-USE OVERLAY DISTRICT. Within the boundaries of the COMMERCIAL / MIXED-USE OVERLAY DISTRICT, the rules and regulations set forth in this PD, PLANNED DEVELOPMENT DISTRICT are modified as follows:

A. GENERAL:

1. BUILDING HEIGHT.

- a. Any building constructed within the COMMERCIAL / MIXED-USE

OVERLAY DISTRICT shall be at least two (2) stories in height or have the appearance of being at least two (2) stories in height, if a single story.

2. MAXIMUM BUILDING AREA.
 - a. The maximum building area that may be dedicated to a single commercial use shall be 2,500 square feet, except as provided below:
 - i. The maximum building area for a corner market shall be 5,000 square feet.
3. ADDITIONAL PERMITTED USES. In addition to the residential uses permitted by-right in Paragraph (A) of SITE AND BUILDING STANDARDS SPECIFIC TO SINGLE-FAMILY ATTACHED (BROWNSTONES) as set forth in this PD, PLANNED DEVELOPMENT DISTRICT, the additional uses provided below are also permitted. Multiple uses per a building and lot are permitted.
 - a. Artist Studio.
 - b. Corner Market.
 - c. Food Service Establishment, provided the specific use shall be limited to:
 - i. a Bakery (no drive-through);
 - ii. a Café (no drive-through);
 - iii. a Coffee Bar (no drive-through); AND
 - iv. a Restaurant (no drive-through).
 - d. Live-work (the maximum number of employees and occupants shall be 4).
 - e. Mail Center.
 - f. Mobile Food Vendor Park.
 - g. Office (the maximum number of employees and occupants shall be 4).

- h. Personal Service Establishment, provided the specific use shall be limited to:
 - i. a Barber, Hairdresser, or Salon (the maximum number of chairs shall be 2); AND
 - ii. a Tailor.

4. ADDITIONAL USE RESTRICTIONS.

- a. Corner Market:
 - i. a minimum of 50 percent of its total retail sales and display area shall be dedicated exclusively to the sale of food and beverages intended for home preparation and consumption;
 - ii. a minimum of 50 percent of its total retail sales and display area shall be dedicated exclusively to the sale of perishable goods including but not limited to: dairy; fish; meat; and poultry; AND
 - iii. a maximum 10 percent of its total retail sales and display area of the corner market may be devoted to the sale of alcohol, exclusively for off-site consumption;
 - iv. the building area for commercial enterprise is limited to the first story;
 - v. the retail sale of discount and used merchandise is prohibited; AND
 - vi. the hours of operation shall be limited from 7:00 A.M. to 9:00 P.M.
- b. Food Service Establishment:

- i. the food service establishment shall be further restricted to seating no more than 40 patrons; AND
 - ii. the hours of operation shall be limited from 7:00 A.M. to 9:00 P.M.
 - c. Live-work:
 - i. the building area for commercial enterprise is limited to the first story;
 - ii. the business owner must reside at the property; AND
 - iii. the hours of operation shall be limited from 7:00 A.M. to 9:00 P.M.
 - d. Office:
 - i. the building area for commercial enterprise is limited to the first story;
 - ii. the business owner must reside at the property; AND
 - iii. the hours of operation shall be limited from 7:00 A.M. to 9:00 P.M.
- 5. OUTDOOR SEATING AND OUTDOOR SERVING.
 - a. Commercial uses may utilize the area located between a building façade and the vehicular lanes for outdoor seating and outdoor serving, provided that a minimum 6-foot contiguous clear path be maintained.
 - b. Commercial uses shall not utilize the area located between a building façade and the vehicular lanes for outdoor display of merchandise.
- 6. PROHIBITED USES. Any use not listed in Paragraphs (A)(3) shall be prohibited

within this COMMERCIAL / MIXED-USE OVERLAY DISTRICT.

7. MINIMUM REQUIRED PARKING (COMMERCIAL USES ONLY).
 - a. Office:
 - i. 3.0 assigned parking spaces per 1,000 square feet of net office space.
 - b. All Other Commercial (Retail) Uses:
 - i. 3.0 assigned parking spaces per 1,000 square feet of net retail space.
 - ii. Retail spaces under 1,500 square feet shall be exempt from the parking requirements in this Paragraph (A)(6).
8. ADDITIONAL PARKING REQUIREMENTS.
 - a. Parking lots shall be located to the rear or the side of buildings.
 - b. Parking lots shall not provide more than 20 parking spaces.
 - c. Parking lots may be paved with pervious materials.
 - d. Parking lots shall be accessed by rear alleys where available.
 - e. Parking provided shall include the actual parking spaces provided within the lot and along the adjacent thoroughfare.
9. ADDITIONAL SIGNAGE REQUIREMENTS. Signage for commercial uses shall be designed in accordance with the following and are expressly limited to the sign types provided below.
 - a. General:
 - i. All signage shall be externally illuminated.
 - b. Sign band:

- i. One external permanent sign band may be applied to the exterior wall of each building, and not to exceed 3 feet in height, provided there is a shopfront building frontage is provided at the first story.
- c. Blade signs:
 - i. One blade sign for each first story business, no more than 6 square feet each, may be permanently installed perpendicular to the building wall.
 - ii. Blade signs shall clear eight feet above the sidewalk.
 - iii. Businesses on corner lots may install one blade sign per frontage.
- d. A-frame sidewalk signs:
 - i. One A-frame sidewalk sign not to exceed 6 square feet, may be placed in front of a first story business during business hours
 - ii. A-frame sidewalk signs shall be made of wood or metal and shall have a hand-crafted design.

MISCELLANEOUS STANDARDS:

- A. **BUILDING MECHANICAL AND ROOFTOP MECHANICAL EQUIPMENT.**
 - 1. Building mechanical equipment including, but not limited to, electric meters, gas meters, water meters, and transformers and refuse storage shall be visually screened.

2. Rooftop mechanical equipment shall be visually screened from all sides by parapet walls or opaque screening enclosures, both of which shall be a minimum of twelve (12) inches greater in height than the equipment.

B. COLLECTION RECEPTACLES.

1. All collection receptacles shall be visually screened on all sides by a solid, opaque wall a minimum of six feet in height, and constructed of a material matching the nearest building wall to the satisfaction of the Director of Planning. All access doors into the collection receptacle shall be made of opaque metal matching the height of the solid walls.

C. MANDATORY PROPERTY OWNERS' ASSOCIATION.

1. A mandatory property owners' association shall be recorded in the public records of Tarrant County, Texas, and shall be binding upon all purchasers of land within development. The mandatory property owners' association shall be responsible for the maintenance of all on-site parking, lighting, landscape, irrigation, fences, walls, gates (non-vehicular, access control systems, storm water quality and detention systems, private streets, and civic space and amenities.

PHOTOGRAPH NO. 1.



PHOTOGRAPH NO. 2.



PHOTOGRAPH NO. 3.

